



B85 BLUELIFT

The BLUELIFT Series

Italian manufacturer Bluelift features the first ever compact lift which is truly a hybrid powered boom, combining a lithium battery with a combustion engine.

With these unique power choices, the lift works safely indoors with the lithium battery and outdoors with the onboard gas or diesel powered generator.

Innovative electro-hydraulic system allows operators two independent functions simultaneously, with smart wireless controllers.

Model	B85
Working height	85'- 5"
Basket height	79'- 5"
Max outreach	47'- 7"
Basket capacity	550 lbs
Basket dimensions	54½" x 32"
Basket rotation	+/-80°
Turret rotation	360°
Height	6'- 6"
Length (w/o basket)	16'- 11"
Length (w/ basket)	18'- 3"
Width (w/o basket)	38"
Footprint	Variable
Weight (approx)	7,599 lbs
Max pressure, footplate	109 psi
Foot pad size (per pad)	48½ sq-in
110V drive motor	Standard
Honda gasoline engine	Standard
Hatz diesel engine	Option
Lithium battery	Option

We reserve the right to alterations

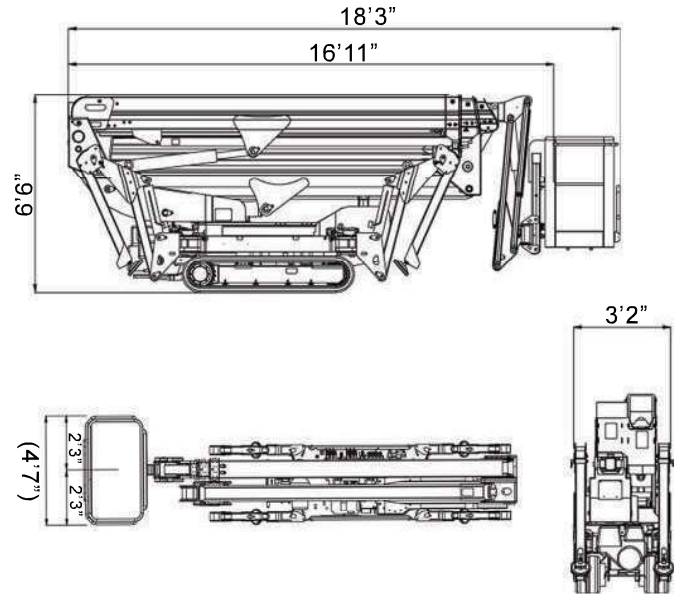
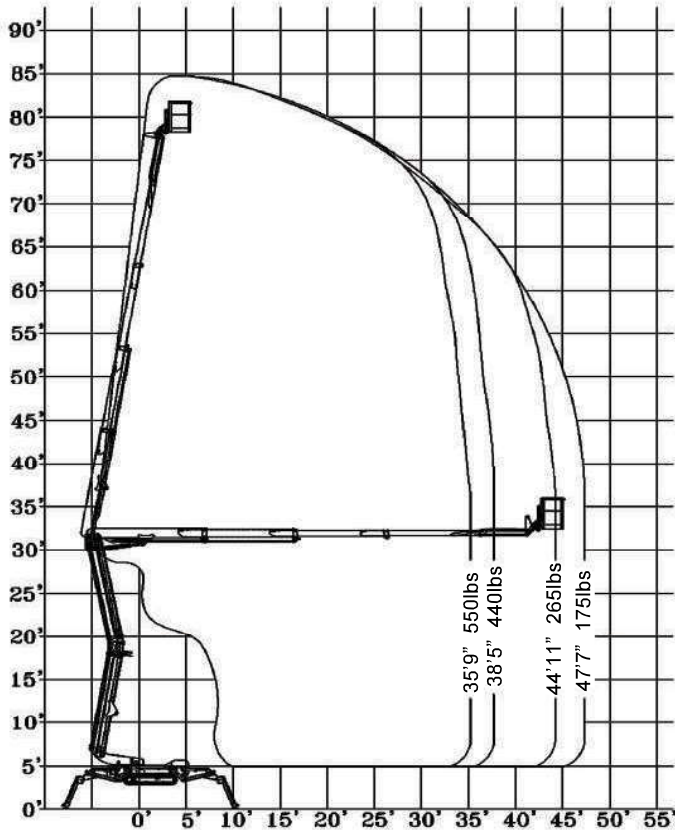

Outrigger Positions

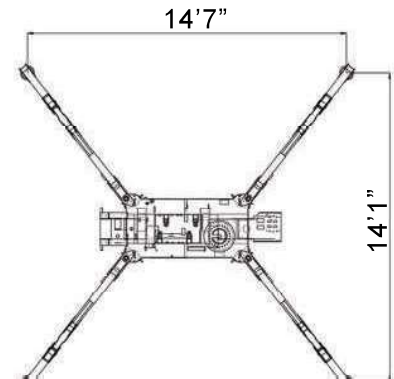
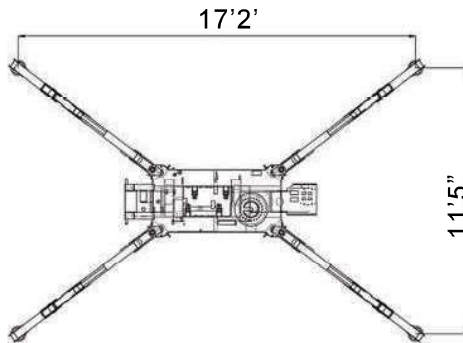
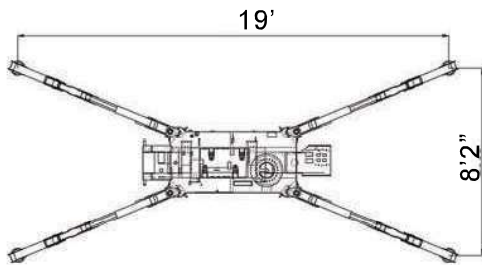

Standard Equipment

- Honda iGX440 15HP engine
- Hetronic radio remote control
- Hetronic control fixed in basket
- Self stabilizing system
- 110V to basket
- Automatic outrigger setting
- Air/water to basket (1 tube)
- Track width adjusting system
- Set up on uneven surfaces
- Automatic turret center stop

Optional Equipment

- Hatz diesel engine
- Lithium battery
- One man basket
- Anti-entrapment system
- GO home function
- Kit for orange LED on outriggers

